

**FIRST IN FEEDERS AND AIRLOCKS**

## WHO ARE WE ?

Anval an ISO 9001: 2008 company has built a reputation as the market leader in the design and manufacture of valves, feeders and airlocks. Born from the Australian thermal processing specialist Ansac, Anval is able to draw from over 30 years of industry experience to deliver the highest quality equipment into some of the most demanding applications in the world.

Anval are constantly developing and widening their range of equipment to cater for the increasingly demanding needs of their customers. While most industries routinely handle powdered substances en-mass, each material will have specific needs that will need to be tailored to ensure efficiency is maintained. From simple powder to raw coal, from sticky biomass to abrasive alumina. Anval's in-house engineering teams have provided solutions to a dazzling array of material handling problems.

Anval prides itself on using simple and robust design solutions to effectively fulfill customer's performance requirements. Committed to customer satisfaction, Anval will not only provide an effective design solution, but will also ensure spare parts supply and full service support throughout the life time of the product.

## WHY US ?

Being a customer centric organization, Anval believes in providing high quality, customized products and services to facilitate customer's business model in all possible ways.

The simplicity of the Anval designs means a relatively low maintenance requirement even under harsh operating conditions.

Our products and solutions have proven themselves across a wide range of industries and in some of the most demanding applications. We are proud to be the preferred suppliers of valves for the world's top mining and bulk material handling companies.



### SIMPLE, STABLE & ECONOMICAL AIRLOCKS

## RL SERIES | Rotary Airlocks & Feeders

Rotary air lock valves have applications in the control of both solid gas separation applications and solids metering. RL Series valves are ideally suited for air locks on dust collection systems or solids feeding applications and can service a very wide range of industries and applications. Comes in varied sizes from 150mm to 300 mm.

- Robust design & cost effective
- No complex adjustments
- Minimum maintenance requirements
- Available in direct/chain drive types
- Excellent airlock performance
- Equipped with replaceable "Labyrinth Seals"

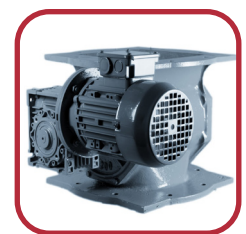

## THE CORROSION RESISTANT VALVES

### RS SERIES | Rotary Airlocks & Feeders

Anval RS series rotary valves are in complete cast Stainless Steel construction with internal surfaces machined to high precision. These valves are ideally suited for chemical, plastic, animal feed, milling, metallurgy, flour-mills and other food industries to counter corrosion rust or stain problems. Comes in varied sizes from 150 mm to 300 mm as standard and customisable in larger sizes.

- Available in direct or chain or inline drive arrangements
- Mirror finish internals
- Minimal maintenance
- Can be customised to specific requirements
- Equipped with replaceable "Labyrinth Seals"
- Wide selection of rotors
- Suitable for Food and Pharma industries.



## THE HIGH EFFICIENCY BLOW SEALS

### BH SERIES | Rotary Blow Through Valves

BH Valves are uniquely designed for the pneumatic conveying systems to achieve a smoother flow of materials. Our BH series valves are used in the food, flour, grains, plastic, chemical, pharma and milling industries. Available in the range of opening sizes from 150 to 350 mm. Suitable for non abrasive products & can eliminate pressure drop to virtually minimal.

- Designed for pneumatic conveying systems
- Achieves the smoother flow of materials
- Easy to install and maintain
- Compact, simple and robust design
- Single piece cast construction
- Universal Flanges
- Equipped with replaceable "Labyrinth Seals"

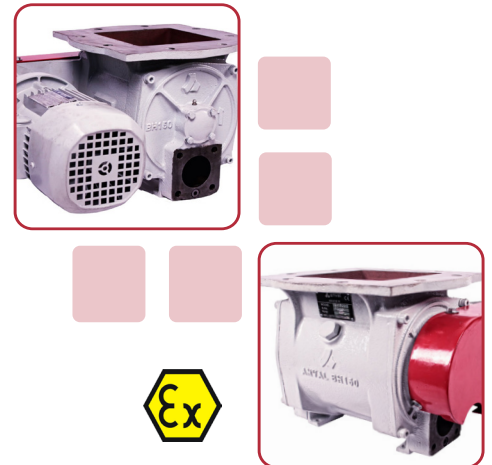

## THE CORROSION RESISTANT BLOW SEALS

### BS SERIES | Rotary Blow Through Valves

Anval BS series rotary valves are in complete cast Stainless Steel construction with internal surfaces machined to high precision. These valves are ideally suited for chemical, plastic, animal feed, milling, metallurgy, flour-mills and other food industries to counter corrosion rust or stain problems. Comes in varied sizes from 150 mm to 300 mm as standard and customisable in larger sizes.

- Mirror finish internals
- Designed for pneumatic conveying systems
- Achieves the smoother flow of materials
- Easy to install and maintain
- Compact, simple and robust design
- Equipped with replaceable "Labyrinth Seals"
- Single piece cast construction
- Universal flanges



LOW COST, HIGHLY EFFECTIVE FLAP VALVES FOR HIGH PRESSURE CONDITIONS  
**DH SERIES | Dump Valves**

Our DH series dump valves are available in opening sizes ranging from 150 to 350 mm for handling large particles & positive sealing under vacuum or pressure conditions. Dump valves are Intended for applications where total sealing & occasional or regular discharge of solids is required.

- Available in wide range of options Gravity fed/Motorised/Pneumatic operations
- Minimum maintenance & long service life
- Easy to install and maintain
- Double seals with outrigger
- Heavy-duty cast iron construction

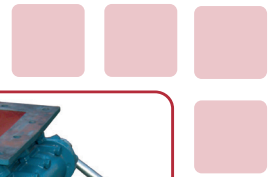

A SIMPLE, ROBUST AND ECONOMICAL ISOLATION UNIT

**SL SERIES | Slide Gate Valves**

The SL Series Slidegate valves can be fabricated to opening size ranging from 150 to 300 mm. The units can be actuated manually or pneumatically and are a self contained and self supporting unit. Customised stainless steel valves can be provided as an alternative to the default mild steel valve.

- Economical and reliable solution for bulk material isolation
- Available in Manual and Pneumatic actuation.
- Compact, simple and robust design
- Pressure tight support frame
- Built to eminent temperature
- Easy to install and maintain

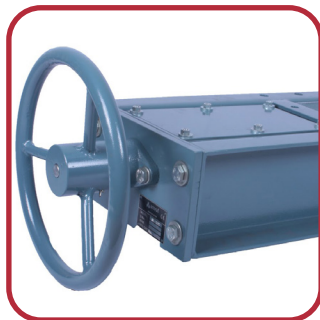

THE ABSOLUTE ISOLATION FOR SOLIDS APPLICATIONS

**SG SERIES | Slide Gate Valves**

Our SG series Slide Gate valves are designed to provide a quick acting isolation valve unit for handling bulk solids to stop material flow. This objective is achieved through the forcing of the blade into the valve seat by trigger lock. Comes in varied sizes as per customer's requirements.

- Heavy duty isolation
- Manual, Pneumatic & Motorised actuation
- Compact & robust design
- Can withstand higher temperature
- Operates under variable pressure
- Easy to install and maintain
- "Anval Trigger Lock Technology" for absolute sealing

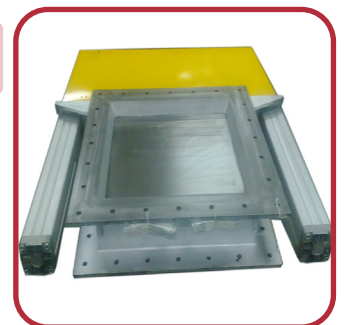

THE HIGHLY EFFICIENT & HEAVY DUTY

## RH SERIES | Rotary Airlock & Feeders

Anval RH series valves are ideally suited as airlocks on dust collection systems or solids feeding applications and can service a very wide range of industries and applications. Comes in varied sizes from 150 mm to 750 mm & even above if needed.

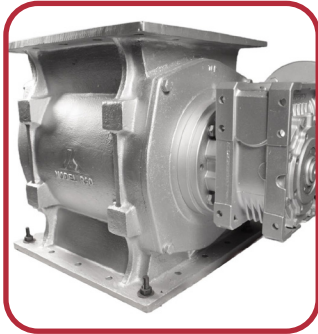

- Heavy-duty cast iron construction
- Available in a range of speeds
- Minimal maintenance
- Available in Direct or Chain drive options
- Can withstand higher temperature
- Equipped with replaceable "Labyrinth Seals"
- Higher pressure handling capability
- Wide selection of rotors
- Can be customised to specific requirements
- Available with Gas or Grease purging

HANDLING OF STICKY, VISCOUS AND NON-FLOWING BULK SOLIDS

## RSC SERIES | Self Cleaning Rotary Airlock & Feeders

RSC Series are specifically designed and well-suited to handle any high-moisture or sticky product application. The self-cleaning function mechanically empties out the pockets and return pushes the easy flow of material. Thus, increasing operational efficiency and reducing downtime in highly demanding applications across industries.

- Equipped with replaceable "Labyrinth Seals"
- Single piece cast construction
- Direct drive construction
- Comes in varies opening sizes
- Achieves the smoother flow of material
- Minimal maintenance
- Excellent airlock performance

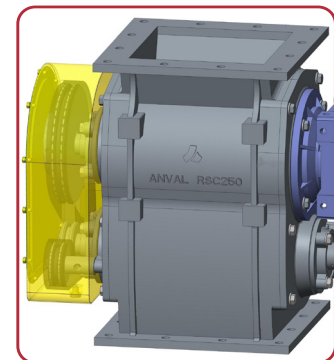

THE CORROSION RESISTANT VALVES FOR QUICK AND EASY CLEANING

## RE SERIES | Rotary Easy Clean Valves

Anval RE series rotary valves permits safe, tool-less removal of the rotor and end plate as one single piece. These valves are in complete cast Stainless Steel construction with internal surfaces machined to high precision and are ideally suited for food, mineral, plastics, pharma, chemical & other contamination sensitive applications, where frequent disassembly, cleaning is required. Comes in varied sizes from 150 mm to 300 mm as standard and customisable in larger sizes.

- Investment casting with excellent mirror finish internals
- Easy Reassembly, Rotor cleaning and Assembly
- "Labyrinth Seals" for high degree of shaft sealing
- Easy to install and maintain
- Compact, simple and robust design
- Direct Drive construction
- Available in Gas or Grease purging options



## THE TOUGH, CERAMIC TIPPED WEAR RESISTANT RFS SERIES | Rotary Floating Shoe Valves

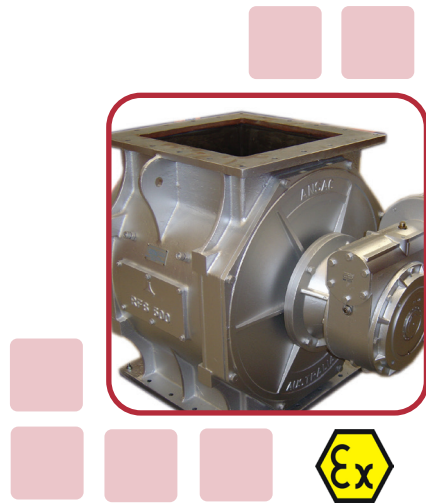

The RFS Series body is built from a single piece of hard wearing cast iron with bolts on side plates and a rotating, webbed rotor set within the body. This unique design enables the valve to operate efficiently in both positive and negative pressure environments. In most cases the Anval Rotary Floating Shoe Series Valve offers up to 4 times the life of a standard Rotary valve, providing unparalleled value for high wearing applications. Comes in varied sizes from 250mm to 750mm as standard & customisable in larger sizes.

- Ultra heavy duty cast iron construction
- Ceramic tipped rotor to minimise wear
- Adjustable, hardened SG iron shoe operation
- Available in direct drive or chain drive
- Can withstand higher temperature
- Higher pressure handling capability
- Available in a range of speeds
- Can be customised to specific requirements

## THE HEAVY DUTY ROTARY VALVES FOR EXPLOSIVE ATMOSPHERE RHX SERIES | ATEX Zone 20 Rotary Airlocks & Feeders

The Anval RHX Series valves are manufactured to robust design standards and an efficacious Quality Management System that enables the valve to operate under even the toughest conditions with minimal maintenance. These valves are driven by ATEX certified geared motors for both direct and chain drive options, alternatively the valves can be supplied as 'Bare Shaft'.

RHX Series Rotary valves are recommended for use in potential Explosive Atmosphere when handling materials like Coal, Alumina powder, Sugar and other inflammable/Explosive chemicals.

- ATEX Zone 20/21 with protection by "Construction Safety"
- Heavy duty single piece cast iron body
- Available in Direct / Chain / Bare Shaft options
- Wide selection of rotor types
- Equipped with "Labyrinth Seals" for improved sealing
- Available with Gas or Grease purging
- Excellent Airlock performance
- Minimal maintenance requirement

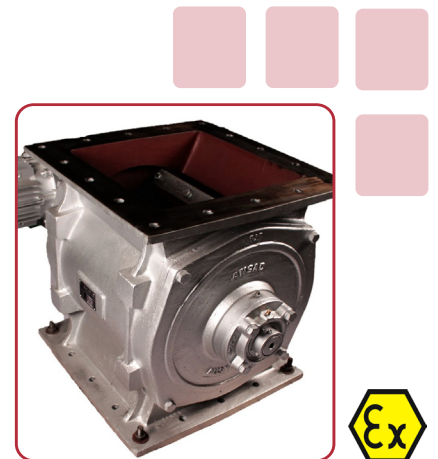

Authorized Distributor:



**Transmin HEAD OFFICE Western  
Australia Office:**

Ph: 1300 127 091  
Address: 33-37 Denninup Way  
Malaga, Perth, Western Australia, 6090